

3D CAD:

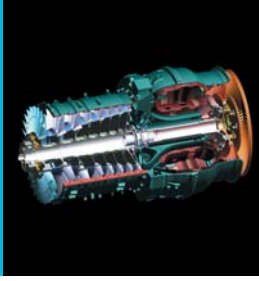

cost effective solutions

Aerospace

Ship Building

Automotive

Petrochemical

Resource Engineering Projects (REP) CAD/CAM / DMU division provides engineering support for programs, offering bespoke rapid response support to engineering sectors.

We recognise that businesses today operate with shorter lead times and tighter deadlines. REP can support your additional capacity requirements by providing a flexible solution.

REP works with clients to provide CAD services as an extension of their business, working as an integral part of the client organisation to deliver a right first time, hassle free result.

With the experience and expertise of our engineers, REP provides on and off site support, by adding an individual to an existing team or managing a fixed price project in our facilities, the choice is yours.

Services

REP offer a full range of services from 2D to 3D conversions, from 2D paper drawings to 3D modelling, even 3D to 3D from one software format to another. These services are offered across the Aerospace, Shipbuilding and Automotive sectors, from basic mechanical models to bespoke VIP aircraft interiors and complex aero engine components.

REP also have expert knowledge in HVAC for the Petrochemical and Shipbuilding industry performing 3D network routings of pipe work for power plants, routing for HVAC and electrical services including the bill of materials. As well as 3D libraries for catalogues across all sectors.

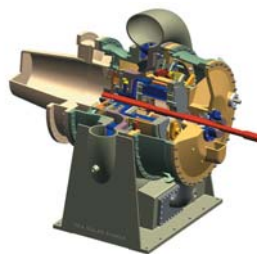
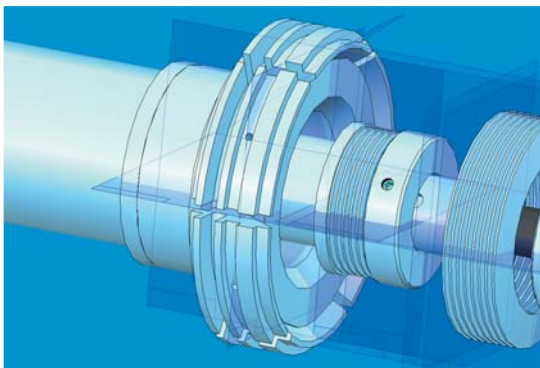

Software

REP currently support numerous software programs to facilitate our various clients work including:

- CATIA V4 & V5
- SolidEdge
- UG NX
- Solidworks
- AutoCad
- ProENGINEER

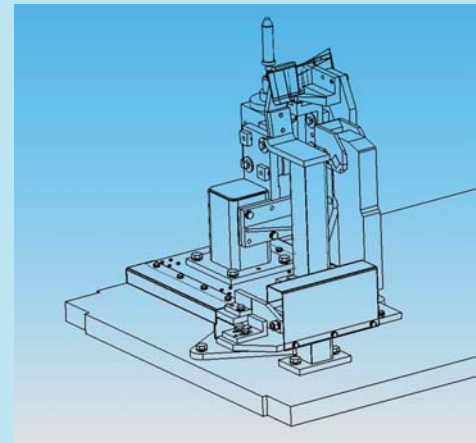

Contact us:

The Kays Building
23 The Tything
Worcester
WR1 1HD
United Kingdom

Tel: +44 (0)845 375 2500
Email: REP@resourcegroup.co.uk
Web: www.resourcegroup.co.uk/REP

REP also provide services for PLM, CAD, DMU, Project Management & Contract Supply



Lufthansa Resource
Technical Training

Contractair



Resource Engineering Projects is a division of
Resource Group